

TECHNICAL DATA SHEET

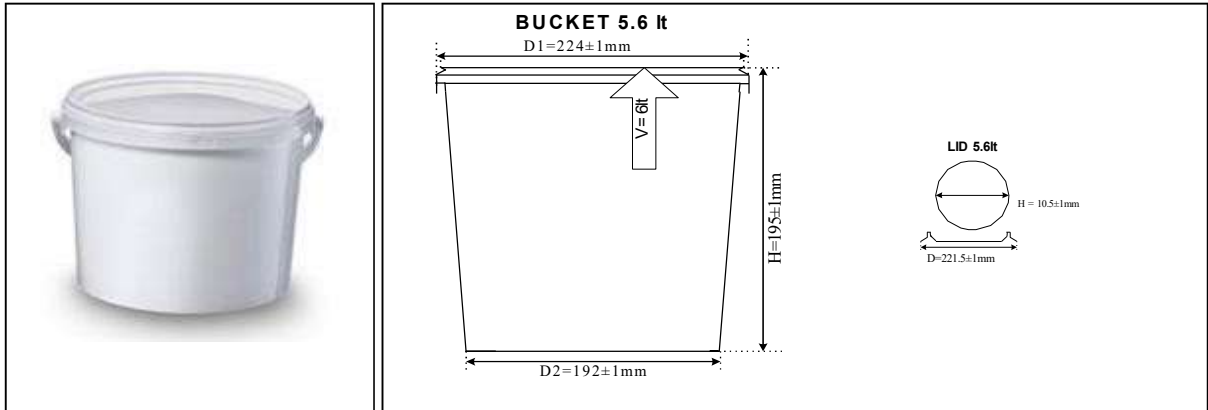

PRODUCT: TB560 / v.5 (05-20)



DECORATION		PRODUCT INFORMATION	
BUCKET		Capacity	5.6 Lt
In Mould Label		Bucket weight	144 ± 5.8 gr
Length (mm)	639	Lid 5.6lt weight	37 ± 1.48 gr
Width (mm)	173	PALLETISING	
LID		Pallet dimensions (mm)	800x1200
In Mould Label		Buckets per pallet	875
Diameter(mm)	198	Lids 5.6lt per pallet	875

GENERAL INFORMATION



Containers and lids are produced by Polypropylene in grades approved for food packaging according to European Regulation 10/2011, 1935/2004, 2023/2006 (and their modifications). Overall and specific migration controls are carried out in according to European Regulation 10/2011. The products are mainly available in white, in various other colors after order and with plastic handle.

STACKABILITY

Suggested stacking (static load):
 *4 buckets in height
 *15 buckets per layer
 *Max 5.5kgr per bucket







Stackability depends on many factors and the above data is meant as an indication only. Consequently, customers should make internal trials to determine the viability of stacking and transportation

QUALITY CONTROL

ThrAce Plastics Pack Co S.A. is certified in accordance with the requirements of standard ISO 9001, ISO 22000, BRC,FDA and HALAL.

CERTIFICATIONS

ISSUED BY: Q.A Manager APPROVED BY: Plant Manager